



**ZANOTTI Spa**  
 Via M.L. King, 30  
 46020 - Pegognaga (MN) - ITALY  
 Tel. +39 0376 5551  
 Fax +39 0376 536554  
 info@zanotti.com

# Technical specifications

Version 1.48

Model:  
**MSB530EB13XX**

Class:  
**Uniblock SB**

## Technical data

Characteristics	M.U.	Value
Working temperature	°C	+10 ÷ -5
Starting mode		Direct
Voltage	Volt-Ph-Hz	400/3N~/50
Rated input	kW*	3,40
Rated input	Amp*	7,90
Peak current	Amp	69,0
Max current	Amp	16,2
Refrigerant		R134a
	GWP	1430
Defrost		Hot gas
Mass	Kg	151

## Compressor

Type		Hermetic
Nominal power	kW	3,7

## Condenser

Air flow	m³/h	3200
----------	------	------

## Evaporator

Air flow	m³/h	3450
Air throw	m**	10

PED Category		1
--------------	--	---

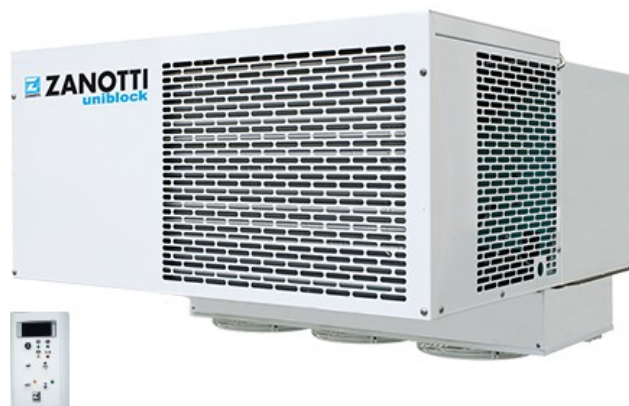

## Power data

Tc °C	Ta °C	P watt	P Kcal/h	V100 m³	V80 m³	V60 m³
	20	8004	6883	109	99	90
	25	7632	6564	102	93	85
10	30	7197	6189	95	86	79
	35	6727	5785	87	79	72
	40	6252	5377	79	72	66
	20	6791	5840	88	80	73
	25	6419	5520	82	75	68
5	30	6037	5192	76	69	63
	35	5647	4856	69	63	57
	40	5250	4515	63	57	52
	20	5698	4900	70	64	58
	25	5217	4487	63	57	52
0	30	4871	4189	57	52	47
	35	4578	3937	52	47	43
	40	4254	3658	47	43	39
	20	4478	3851	51	46	42
	25	4137	3558	45	41	37
-5	30	3819	3284	40	36	33
	35	3523	3030	36	33	30
	40	3252	2797	31	28	26

\* When normally running: 0 ÷ +30°C

\*\* Use air throw as a base. Air throw is affected by many factors such as height of room, product storage, location of evaporator, etc.

Tc: Coldroom temp. - Ta: External temp.

P: Refrigerant capacity - V: Recommended cold-room volume

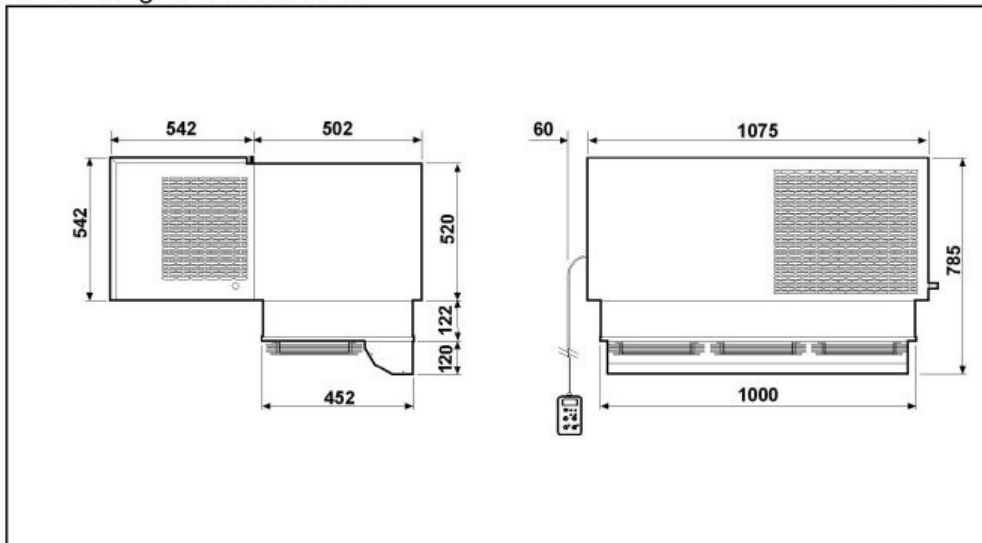

Schema di montaggio - Mounting scheme - Schema de montage  
Montageschema - Esquema de montaje

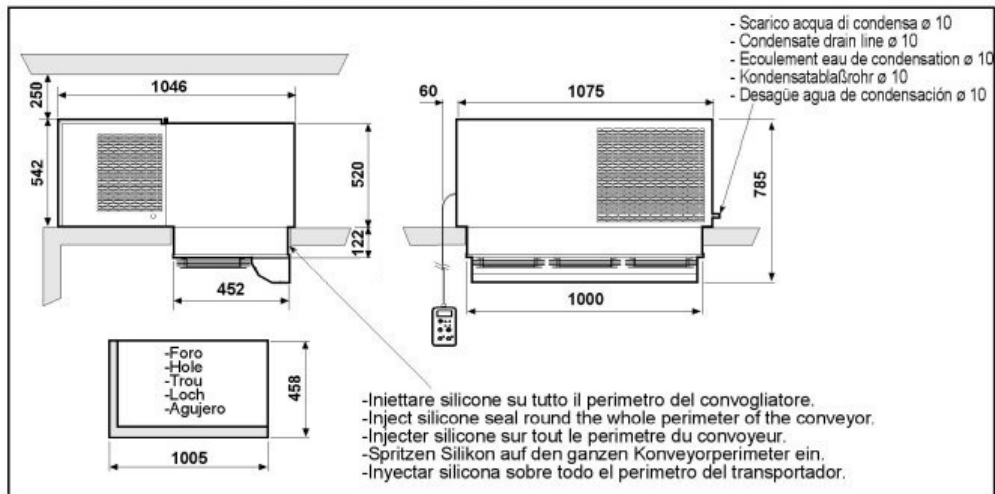

- \* Raccomandazioni in sede di installazione e per il controllo fornite sul manuale di installazione
- \* To be advised at time of order for factory installation and operating instructions
- \* Recommendations au moments d'installations et pour le contrôle fournis sur le manuel d'installation
- \* Empfehlungen für die Installationsphase und zur Kontrolle, die im Handbuch zur Installation enthalten sind
- \* Por cuanto respecta a recomendaciones de instalación y control ver manual de instalación

Massa e misure imballi - Packing mass and dimensions - Masse et dimensions emballages  
Verpackungsmasse und-abmessungen - Masa y medidas del embalaje

